

Porta  **UM**
unified messaging



Installation Guide
Maintenance Release 20

Copyright Notice & Disclaimers

Copyright © 2000-2009 PortaOne, Inc. All rights reserved

**PortaUM Installation Guide, August 2009
Maintenance Release 20
V1.20.1**

Please address your comments and suggestions to: Sales Department,
PortaOne, Inc. Suite #408, 2963 Glen Drive, Coquitlam BC V3B 2P7
Canada.

Changes may be made periodically to the information in this publication. Such changes will be incorporated in new editions of the guide. The software described in this document is furnished under a license agreement, and may be used or copied only in accordance with the terms thereof. It is against the law to copy the software on any other medium, except as specifically provided in the license agreement. The licensee may make one copy of the software for backup purposes. No part of this publication may be reproduced, stored in a retrieval system, or transmitted in any form or by any means, electronic, mechanical, photocopied, recorded or otherwise, without the prior written permission of PortaOne Inc.

The software license and limited warranty for the accompanying products are set forth in the information packet supplied with the product, and are incorporated herein by this reference. If you cannot locate the software license, contact your PortaOne representative for a copy.

All product names mentioned in this manual are for identification purposes only, and are either trademarks or registered trademarks of their respective owners.

Table of Contents

Preface 3

1. Introduction.....4

Hardware and Software Requirements 5

2. Installation Process7

Step 1: Insert USB Dongle..... 8

Step 2: Power-up, Boot Order Setup 8

Step 3: Insert CD-ROM 9

Step 4: Launch Installation Process 9

Step 5: CD Media Test..... 11

Step 6: Welcome Screen 11

Step 7: Choose Installation Type 12

Step 8: Hardware Check..... 12

Step 9: PortaSwitch Parameters..... 13

Step 10: Network Configuration 14

Step 11: Disk Partitioning - Overview..... 14

Step 12: Disk Partitioning - Choose Disk..... 14

Step 13: Disk Partitioning – Slice Layout..... 15

Step 14: UM Mail Domain Configuration..... 15

Step 15: Set Up Root Password and User Account 16

Step 16: Start Installation..... 16

Step 17: Installing Required Applications..... 17

Step 18: Prepare to Reboot..... 18

Step 19: Check If System Can Reboot to Normal State 19

Step 20: Prepare System for Transport (Optional)..... 20

3. Cisco AS5300 Gateway Setup 21

Setting-up Back-to-Back T1/E1 Connection 22

Other Important Considerations..... 24

Preface

This document provides a general overview of the PortaUM installation process.

Where to Get the Latest Version of this Guide

The hard copy of this guide is updated at major releases only, and does not always contain the latest material on enhancements occurring between minor releases. The online copy of this guide is always up to date, and integrates the latest changes to the product. You can access the latest copy of this guide at: www.portaone.com/support/documentation/

Conventions

This publication uses the following conventions:

- Commands and keywords are given in **boldface**
- Terminal sessions, console screens, or system file names are displayed in `fixed width font`



The **exclamation mark** draws your attention to important information or actions.

NOTE: Notes contain helpful suggestions about or references to materials not contained in this manual.



Timesaver means that you can save time by performing the action described in the paragraph.



Tips provide information that might help you solve a problem.

1 . Introduction

PortaUM can potentially run on most modern UNIX operating systems (FreeBSD, Linux, Sun Solaris), assuming these are equipped with basic items such as an ANSI C compiler. However, it might be difficult for an inexperienced system administrator to install and configure the operating system in such a way as to suit all of the requirements and provide the best performance. Installing all the prerequisite software (libraries, Perl modules, etc.) might also be a time-consuming task, with a high risk of making some hard-to-trace error.

The PortaUM JumpStart installation CD provides a quick and seamless way to perform a complete server installation from scratch, in less than 15 minutes. It contains installation media for FreeBSD 6.4, with all the necessary packages and PortaUM itself.

The installation wizard uses a text-mode GUI. Use the arrow keys to change your selection, **Tab** to move between fields, and **Enter** to confirm a choice.

Hardware and Software Requirements



NOTE: If you wish to perform testing to determine whether PortaSwitch can be installed on a specific server, please use the “Hardware Compatibility” CD provided by PortaOne.

You can download the CD image from:

http://portaone.com/resources/hw_test/HardwareCompatibilityCD.iso

Burn it to a CD using any CD-writing program, then boot up from this CD. The PortaSwitch test utility will detect if all of the required components (e.g. network interface) are available and supported by FreeBSD.



NOTE: Should you decide to use a Cisco gateway for processing UM calls, please note that PortaUM requires a **dedicated** Cisco AS 5300/5350.

Cisco Requirements

- 128M RAM, 64M flash, E1 or T1 voice ports, and a sufficient number of DSPs. IOS 12.3.6a (or another from the 12.3 branch).
- AS5300 comes with 4 or 8 T1/E1's. You will not need more than four of them because of the DSP resource limitation for AS5300.
- For a T1 configuration, the maximum voice resource will be 96, and 120 for E1.

Recommended Configuration:

PortaUM:

- CPU:
basic configuration: Pentium4 2.8GHz
advanced configuration: Pentium4 3GHz
- SCSI integrated or add-on hardware RAID controller compatible with FreeBSD 6.4
- RAM: 1GB
- Disks:
basic configuration: at least 50GB of the available disk space (RAID: mirroring or RAID5)
advanced configuration: at least 80GB of the available disk space (RAID: mirroring or RAID5)
- Network interface
- USB Port
- ATAPI or SCSI CD-ROM drive

Please check that the other hardware installed in your server (such as network adapter, RAID controller, and so on) is supported by FreeBSD. You can check this at the FreeBSD website: <http://www.freebsd.org>.

During installation you will be prompted for the network configuration parameters. Please make a decision regarding these before installation, consulting your network administrator if necessary. It is possible that you will have to perform installation while the network is not yet available (from your office, for example, while the servers will be placed in a server hosting center), but you will need to enter the correct data anyway. Please have the following ready:

- IP addresses of the PortaBilling100 master and slave servers
- IP address of the PortaSIP server
- Name of the MX domain designated for the hostname of the machine running PortaUM
- Subnet mask and address of the default gateway
- DNS server address

If you have a hardware RAID controller in your system, configure the RAID – array. The recommended configurations (depending on the amount of hard drives in the system) are as follows:

- 2 disks – RAID (mirroring)
- 3 disks – RAID 1 (mirroring) on the first two disks, third one left as a hot spare

2. Installation Process

Step 1: Insert USB Dongle

Before you start the installation, insert the USB dongle provided into one of the available USB ports. It must remain in place the whole time to ensure normal system operation.

Step 2: Power-up, Boot Order Setup

Turn on the computer which you plan to use as the server. Enter the BIOS setup and make sure that:

- the CD-ROM is first in the list of boot devices
- USB support is enabled

If you are installing a dual-server configuration, start your installation with the master server.

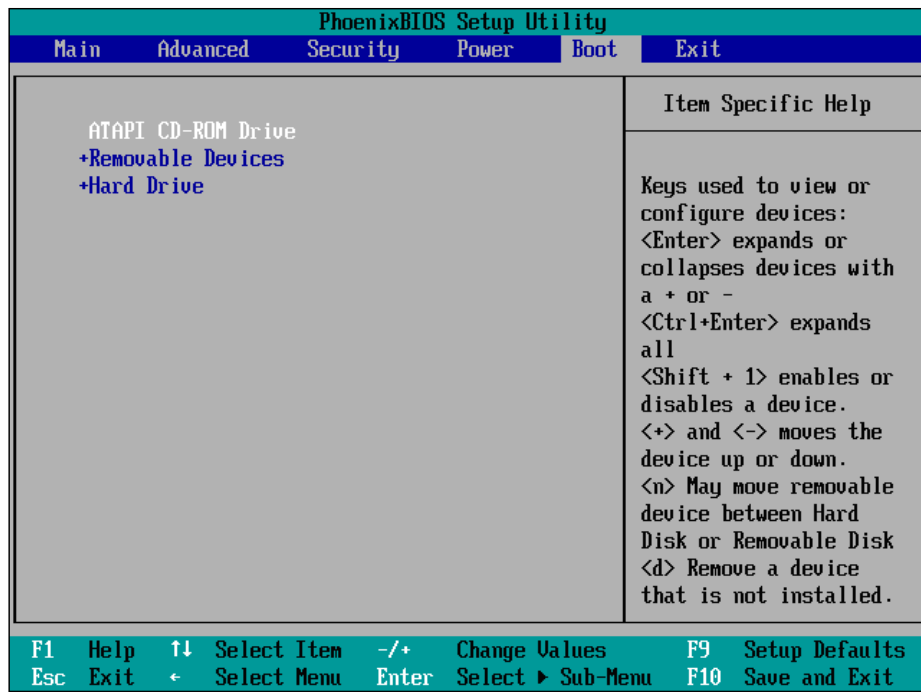

NOTE: This image is only an example. The BIOS on your system might look different.

Save your changes and exit.

Step 3: Insert CD-ROM

While rebooting the system, insert the PortaUM installation CD into the CD-ROM drive. If you do not insert it soon enough and get a “no operating system” error (or a previously installed operating system starts its boot-up process) then press **Reset** and ensure that you are booting from the CD.

Step 4: Launch Installation Process

First, you will be asked to boot from the CD.



You will know that JumpStart installation has begun if you see a screen similar to the following one:

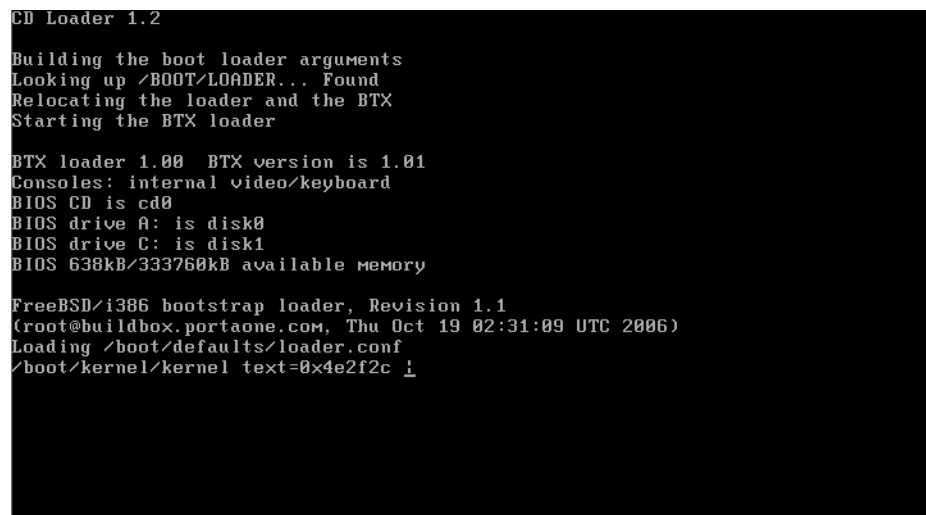

Before proceeding any further, you will see the following screen:

```

Welcome to PortaOne Software installation program!

1. Proceed with PortaUM Installation
2. Disable APIC
3. Disable ACPI
4. Escape to the command line prompt (for advanced users)
5. Reboot

Press 1 or Enter to proceed with installation or [Space] to pause timer 9
```

If you select the first option, installation will start in default mode, which is suitable for most hardware configurations. However, in some cases, option 1 will return a device mounting error due to hardware conflicts. In this case, restart installation and, when you see this screen again, select options 2, 3 or both to enable/disable APIC/ACPI features.

For example, if you are installing to a computer with an ASUS P4VP-MX motherboard, you must disable APIC. In this case, select 2 on the screen above. You will then be shown the disabled features and asked to press 1 or Enter to proceed, as shown in the screen below:

```

Welcome to PortaOne Software installation program!

1. Proceed with PortaUM Installation
2. Enable APIC
3. Disable ACPI
4. Escape to the command line prompt (for advanced users)
5. Reboot

Press 1 or Enter to proceed with installation or [Space] to pause timer 9
APIC disabled
```

Step 5: CD Media Test

Once you start the installation, you will be prompted to check the image file by running a CD Media Test, to make sure it has not been corrupted during download.



Click **Enter** to proceed.

Step 6: Welcome Screen

Next, the installation process starts. First you will see the PortaUM welcome screen:

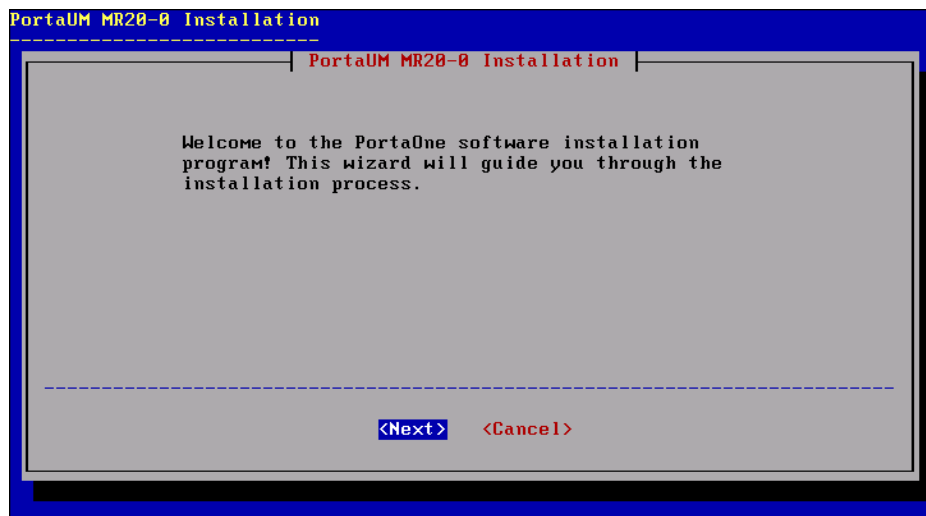

Press **Enter** to proceed.

Step 7: Choose Installation Type

Next you must choose the installation type. This will determine which packages will be installed on this host.

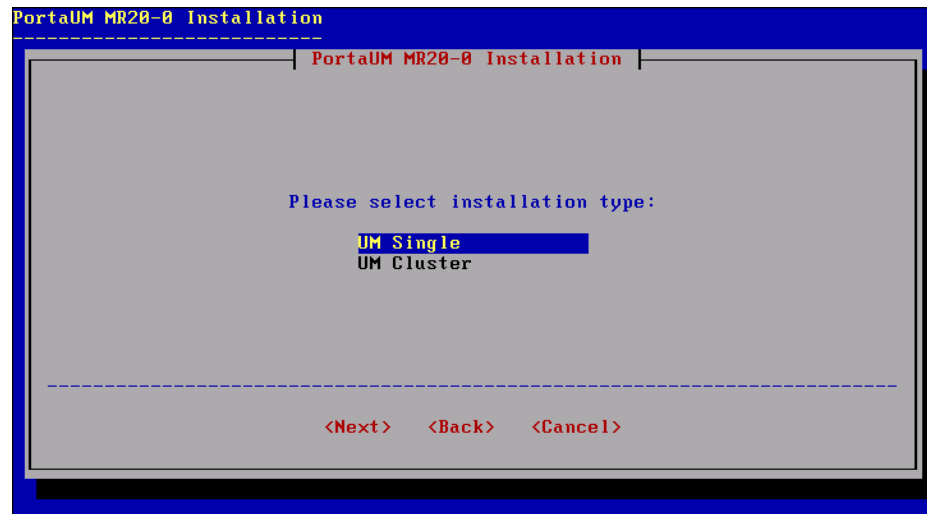

Step 8: Hardware Check

After you have selected the installation type, the system will check your server's hardware components, such as CPU, memory, network card and USB controller.

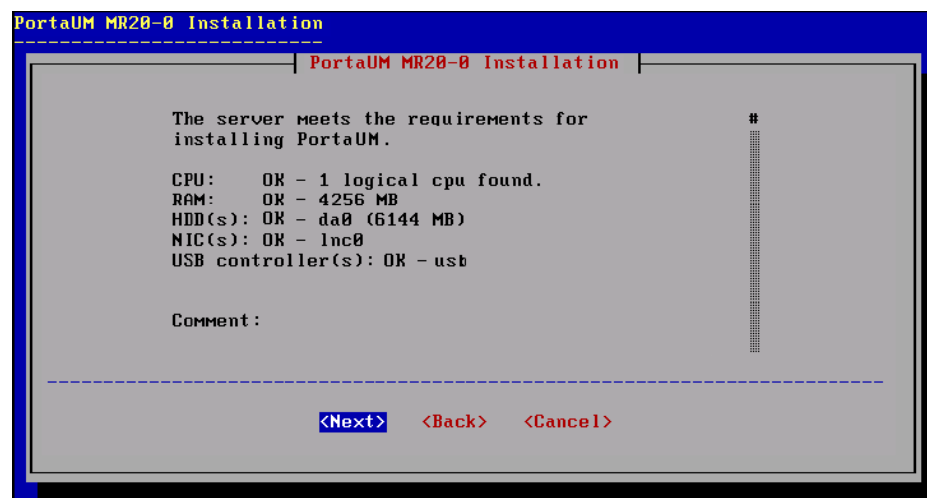

If the hardware test detects a failure, an output message is generated indicating what exactly went wrong when failure occurred.

Step 9: PortaSwitch Parameters

Parameter	Description
RADIUS server	IP address of the PB100 master host.
RADIUS secret	Authentication key for all radius interactions; select a password and write it down, as you will need to enter it later when adding the PortaSIP node to your PB100 system.
RADIUS auth port	Number of the UDP port on which your PortaBilling100 accepts authorization requests
RADIUS acct port	Number of the UDP port on which your PortaBilling100 accepts accounting requests.
RADIUS retransmission interval	Number of seconds to wait for a reply before retransmitting a RADIUS request.
RADIUS retransmission count	Maximum number of retransmissions.



NOTE: Only RADIUS server and RADIUS key are mandatory parameters. You can simply leave the default values for the last four parameters.

```

PortaUM MR20-0 Installation
-----
PortaSwitch Features
-----
PortaBilling100 Master IP: 10.0.0.1
PortaBilling100 Slave IP: 10.0.0.2
PortaSIP IP: 10.0.0.3

Usually, PortaBilling100 Master Server is your RADIUS server.
RADIUS server: 10.0.0.1
RADIUS auth port: 1812
RADIUS retransmission interval: 10
RADIUS key: topsecret
RADIUS acct port: 1813
RADIUS retransmission count: 3

-----
<Next> <Back> <Cancel>
    
```

Step 10: Network Configuration

Fill in the appropriate fields for network configuration in this menu.

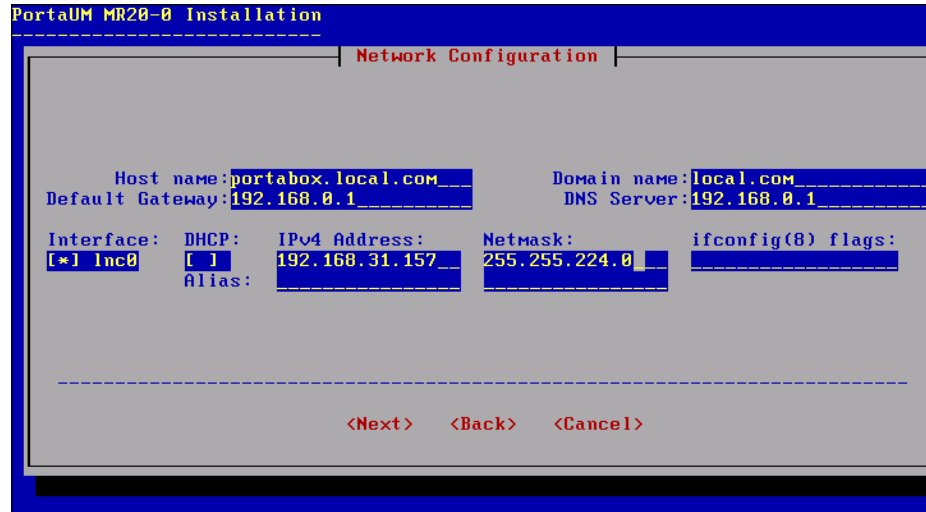

The screenshot shows a terminal window titled "PortaUM MR20-0 Installation" with a "Network Configuration" sub-menu. The fields are as follows:

Host name:	portabox.local.com	Domain name:	local.com						
Default Gateway:	192.168.0.1	DNS Server:	192.168.0.1						
Interface:	<input checked="" type="checkbox"/> Inc0	DHCP:	<input type="checkbox"/>	IPv4 Address:	192.168.31.157	Netmask:	255.255.224.0	ifconfig(8) flags:	
Alias:									

At the bottom of the menu, there are three navigation options: <Next>, <Back>, and <Cancel>.

Use the space bar to set the check boxes for interface and DHCP. Use the Tab key to proceed to the next field. If you have multiple interfaces, set at least one of the interfaces on which your machine connects to the Internet. If you do not use DHCP, unset this box. You can leave the alias and ifconfig(8) flags field empty.

Step 11: Disk Partitioning - Overview

Now you must allocate the hard drive partitions where FreeBSD and PortaUM will be installed. If you have only one hard drive in your system, or have configured your available disks as a single volume array, go to step 13 directly. Otherwise, choose the designated disk in step 12.

Step 12: Disk Partitioning - Choose Disk

If you have more than one disk in your system, you will have to choose which disk you would like to create the FreeBSD partitions on. If in doubt, choose the first disk in the list.

NOTE: Installation is always performed on a single disk. If you want to utilize multiple drives (e.g. install the DB on a separate disk), this can be done after installation.

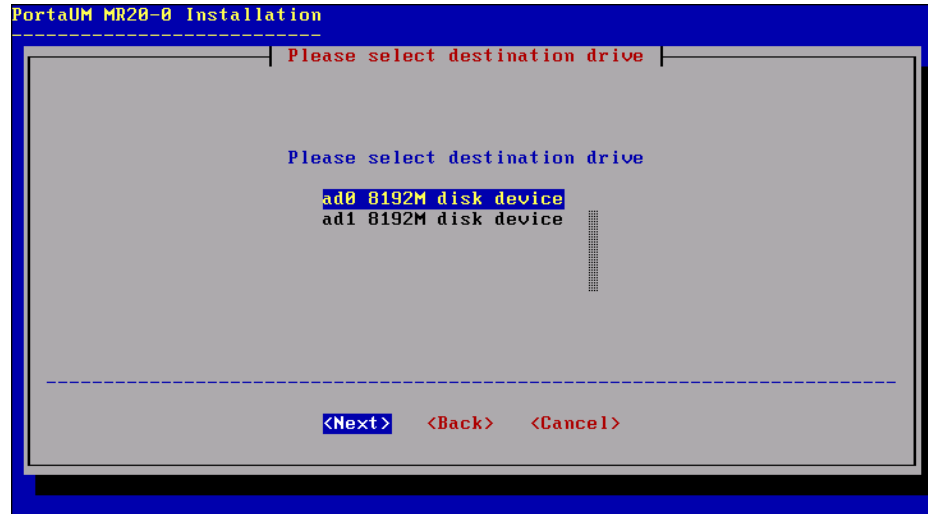

Step 13: Disk Partitioning – Slice Layout

You will be prompted to enter or choose the slice sizes for holding different file systems. The default settings are OK in most cases.

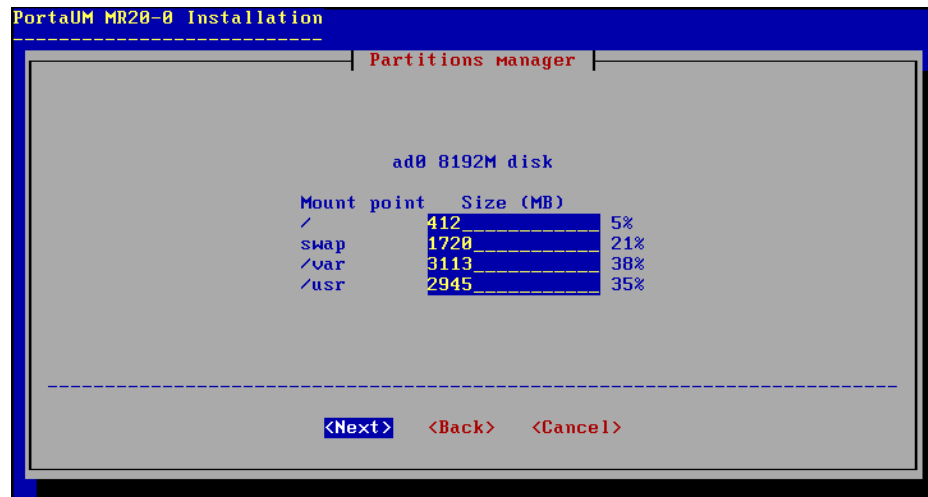

Step 14: UM Mail Domain Configuration

You will need to enter the name of the UM mail domain which you plan to use for PortaUM (i.e. the name appearing after @ in emails sent to/from the PortaUM system). You will also have to register this name in the DNS server for your domain.

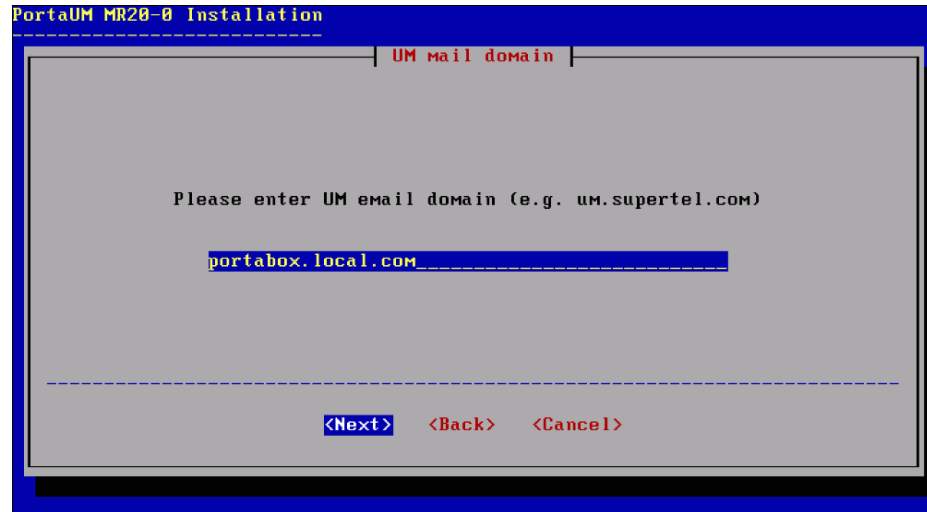

Step 15: Set Up Root Password and User Account

Choosing the super user password is very important, as you will need it to perform system administration or system recovery. Choose a password which is difficult to guess or crack. Add another user account especially for remote administration.

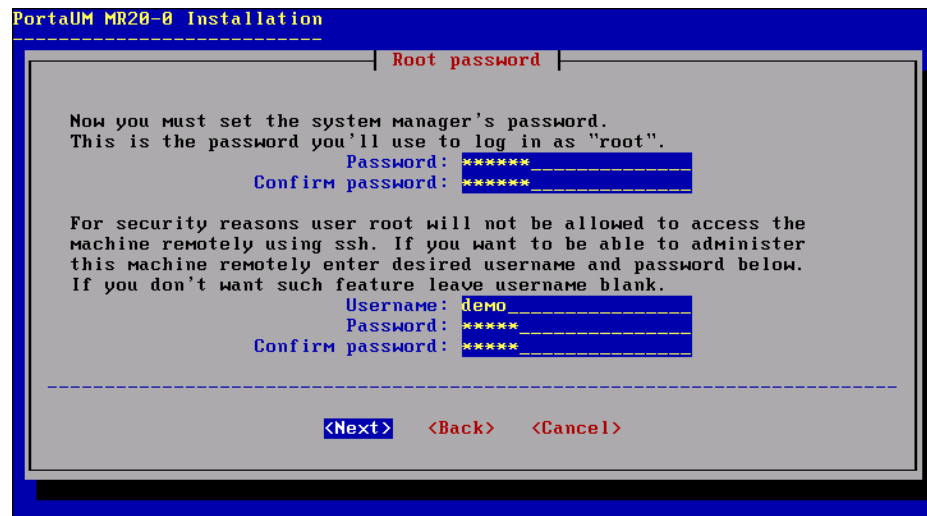

Step 16: Start Installation

Your confirmation is required before the disk layout is changed and the partitions reformatted. Press **Enter** to proceed.

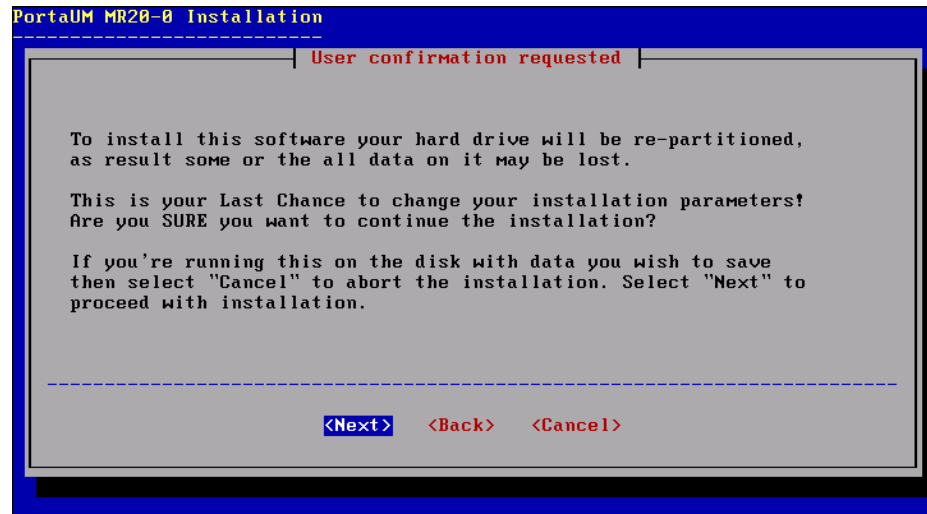

Step 17: Installing Required Applications

When installation starts, you will see a screen similar to the one below. At this step, the installation program will install all the required third-party applications, such as MySQL client and PortaSIP software. This step may take 5-10 minutes.

Progress will be shown on a screen similar to the following one:

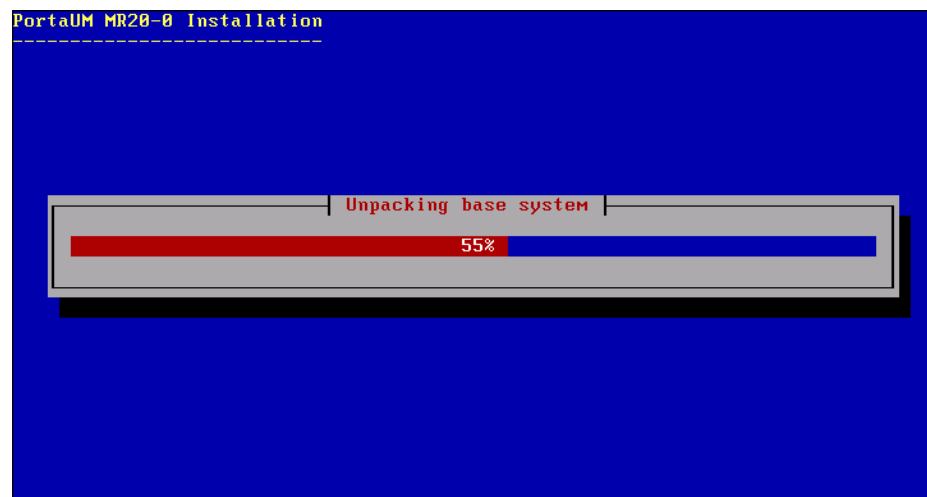

During installation you will be asked to enable UM features on your PortaBilling web interface.

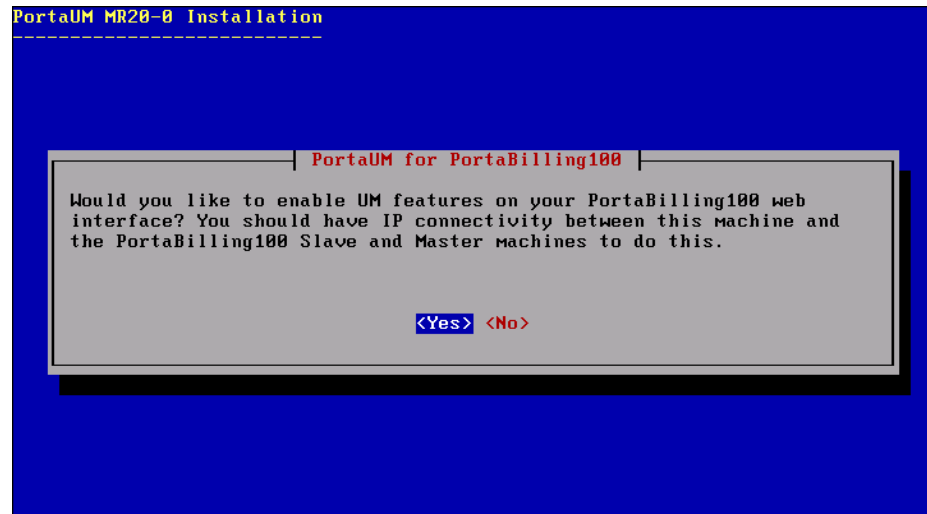

If you select **Yes** on the screen above and do not have IP connectivity to the PortaBilling slave machine, you will be prompted by the following screen. Choose **No** to proceed if you do not have such connectivity.

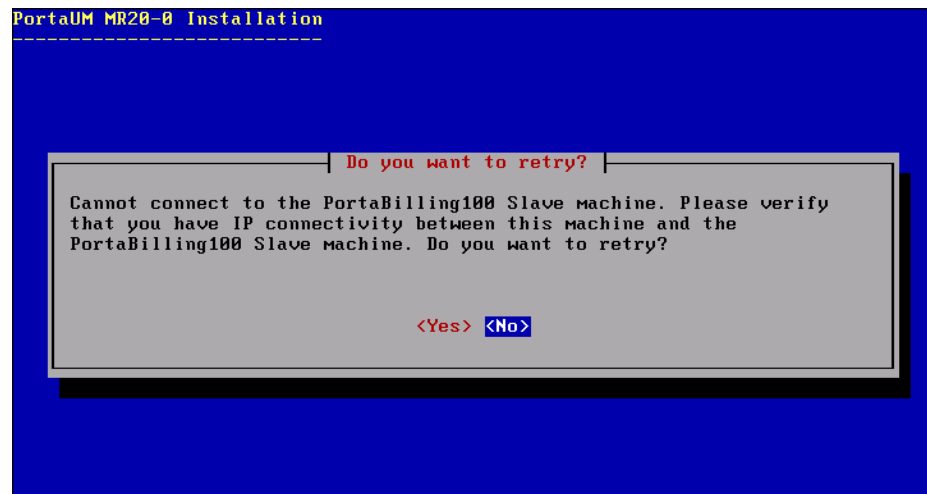

Step 18: Prepare to Reboot

When installation has finished and you reach the following screen, press **Reboot**. After the system has begun its reboot process, remove the installation CD from the CD-ROM.

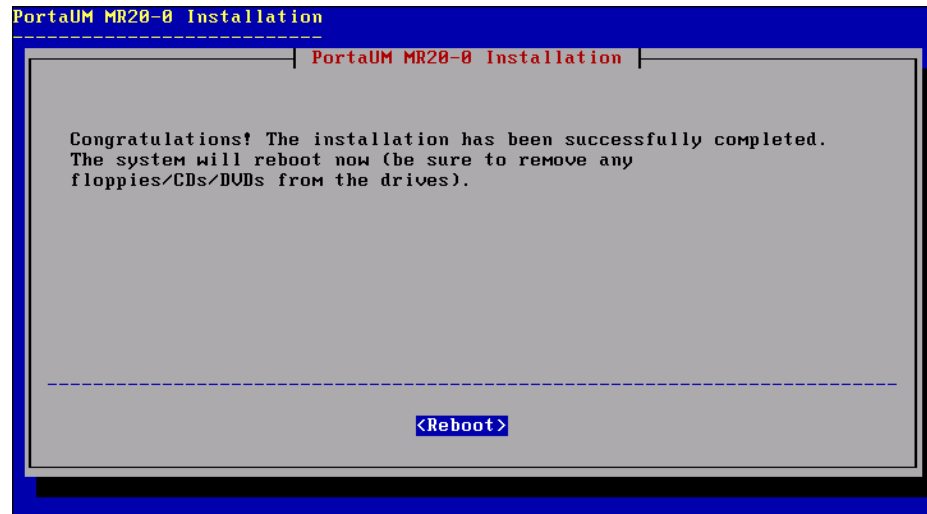

NOTE: Do not forget to enter BIOS again and change the priority of the boot devices so that the hard drive will be attempted first. (This ensures a quicker reboot when recycling the server.)

Step 19: Check If System Can Reboot to Normal State

It is good to make sure that the system is in a stable state, and that it returns to normal operations without intervention on reboot, especially if there is no keyboard or other peripheral attached. Following a normal reboot, the screen should look like this:

```
Starting openssh.  
Starting asterisk.  
All threads purged from ugen0.1  
key is OK  
Performing sanity check of nagios configuration: OK  
Starting nagios.  
Starting mmi_server.  
Starting mf_daemon.  
Starting cyrus_imapd.  
Starting g729d.  
Starting exim.  
Starting apache.  
Configuring syscons: blanktime.  
Starting cron.  
Local package initialization:.  
  
Mon Aug 17 18:52:06 UTC 2009  
  
FreeBSD/i386 (portabox.local.com) (ttyv0)  
login: █
```

Press **Ctrl + Alt + Del** if you need to reboot.

Step 20: Prepare System for Transport (Optional)

If you need to transport the system to another location (e.g. hosting center), or otherwise power down the system safely, proceed as follows:

- Wait until the system finishes booting
- Log in as `root`
- Type `shutdown -p now`
- Wait until either the system powers down on its own or the “The operating system has halted” message appears, and then power off the server.

3. Cisco AS5300 Gateway Setup

Setting-up Back-to-Back T1/E1 Connection

Hardware Setup

In order to use the Cisco AS5300 gateway as a media server and VXML platform in the PortaUM system, you need to physically loop one or more pairs of T1 or E1 voice ports on it, so that these can be used for the PSTN→PSTN connection. To do this, construct one or more RJ-48C cross-over cables using the following table:

T1/E1 CSU/DSU Cross-Over Pinout

From RJ 48C Pin	To RJ 48C Pin
1	4
2	5
4	1
5	2

Make sure you count the RJ-48C pins as shown in the illustration below:

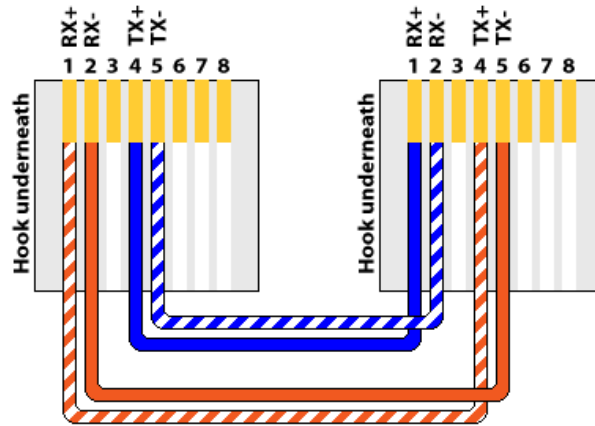

PRI (T1/E1) CrossOver/Loopback Cable

Alternatively, you can order ready-made ones. You can find a number of vendors producing such cables by searching for “RJ-48C cross-over cable” on www.google.com.

Once the cable is ready, plug it into the designated pair of T1/E1 ports in your Cisco AS5300 gateway.

Software Configuration

You must also configure the T1/E1 interfaces. The sample configuration below is for T1; adjust the time slots for E1:

```
isdn switch-type primary-5ess
!
controller T1 0
framing sf
clock source line primary
linecode ami
pri-group timeslots 1-24
!
controller T1 1
framing sf
clock source line secondary 1
linecode ami
pri-group timeslots 1-24
!
controller T1 2
framing sf
linecode ami
pri-group timeslots 1-24
!
controller T1 3
framing sf
linecode ami
pri-group timeslots 1-24
!
interface Serial0:23
no ip address
isdn switch-type primary-5ess
isdn protocol-emulate network
no cdp enable
!
interface Serial1:23
no ip address
isdn switch-type primary-5ess
no cdp enable
!
interface Serial2:23
no ip address
isdn switch-type primary-5ess
isdn protocol-emulate network
no cdp enable
!
interface Serial3:23
no ip address
isdn switch-type primary-5ess
no cdp enable
```

Other Important Considerations

Please ensure that the PortaUM machine and Cisco AS5300 gateway used as a media server and VXML platform have a good network connection between them. Ideally, they should be located on the same 100 Mbps or 1,000 Mbps LAN segment. This is important because the media server needs to load sounds interactively from the PortaUM machine in real time. Therefore, connections with packet loss or transmission delays between the media server and the PortaUM machine can significantly impair service quality. Also, it is likely that there will be a significant amount of network traffic between the media server and the PortaUM machine, which can be quite expensive if they are not co-located.